

Semester 2 (Units 3 and 4) Examination, 2018

Question/Answer Booklet

MATHEMATICS APPLICATIONS

Section Two: Calculator-assumed

Student Name/Number: _____

Teacher Name: _____

Time allowed for this section

Reading time before commencing work: ten minutes

Working time: one hundred minutes

Materials required/recommended for this section

To be provided by the supervisor:

This Question/Answer Booklet

Formula Sheet (retained from Section One)

To be provided by the candidate:

Standard items: pens (blue/black preferred), pencils (including coloured), sharpener, correction fluid/tape, eraser, ruler, highlighters

Special items: drawing instruments, templates, notes on two unfolded sheets of A4 paper, and up to three calculators approved for use in the WACE examinations

Important note to candidates

No other items may be taken into the examination room. It is **your** responsibility to ensure that you do not have any unauthorised material. If you have any unauthorised material with you, hand it to the supervisor **before** reading any further.

Structure of this paper

Section	Number of questions available	Number of questions to be answered	Working time (minutes)	Marks available	Percentage of exam
Section One: Calculator-free	6	6	50	50	35
Section Two: Calculator-assumed	10	10	100	100	65
					100

Instructions to candidates

1. The rules for the conduct of School exams are detailed in the *College assessment policy*. Sitting this examination implies that you agree to abide by these rules.
2. Write your answers in this Question/Answer Booklet.
3. You must be careful to confine your answers to the specific question asked and to follow any instructions that are specified to a particular question.
4. Supplementary pages for the use of planning/continuing your answer to a question have been provided at the end of this Question/Answer booklet. If you use these pages to continue an answer, indicate at the original answer where the answer is continued, i.e. give the page number.
5. Show all working clearly. Your working should be in sufficient detail to allow your answers to be checked readily and for marks to be awarded for reasoning. Incorrect answers given without supporting reasoning cannot be allocated any marks. For any question or part question worth more than two marks, valid working or justification is required to receive full marks. If you repeat any question, ensure that you cancel the answer you do not wish to have marked.
6. It is recommended that you do not use pencil, except in diagrams.
7. The Formula Sheet is not to be handed in with your Question/Answer Booklet.

Section Two: Calculator-assumed

65% (100 Marks)

This section has **ten (10)** questions. Answer **all** questions. Write your answers in the spaces provided.

Supplementary pages for the use of planning/continuing your answer to a question have been provided at the end of this Question/Answer booklet. If you use these pages to continue an answer, indicate at the original answer where the answer is continued, i.e. give the page number.

Working time: 100 minutes.

Question 7

(6 marks)

The population of cats in the town is estimated to be 16 000 and reproducing at a rate of 6.25% per annum.

- (a) To keep the population constant at 16 000 how many cats should be removed from this population each year? (1 mark)

- (b) Determine the first order linear recurrence relation that models the steady-state of the population at 16 000. (2 marks)

- (c) Use the grid to represent the population over the next 10 years. Label your axes. (3 marks)

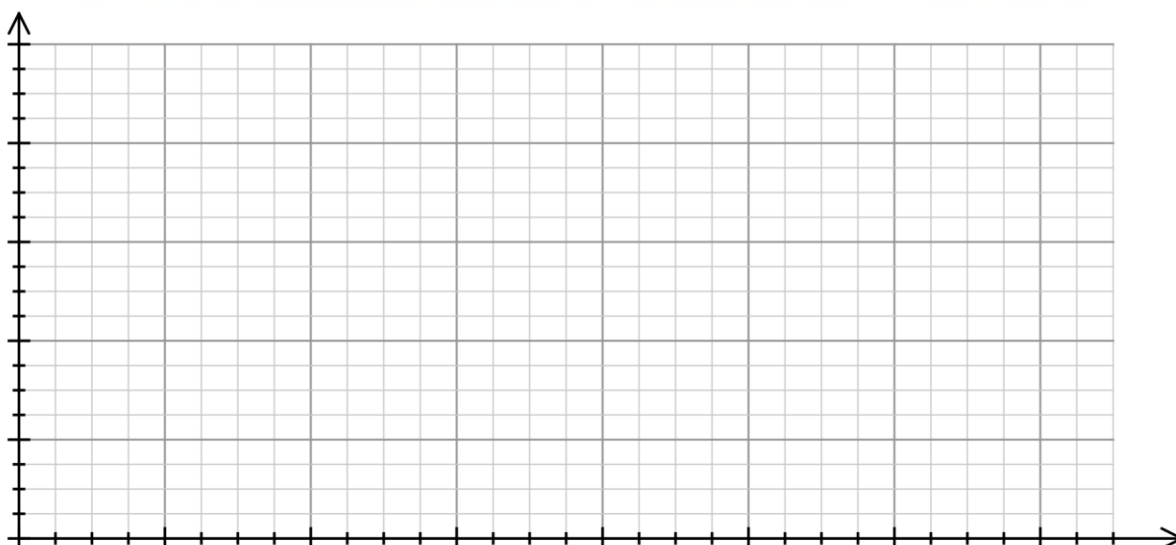

Question 8

(8 marks)

The graph below represents the number of arson offences for each season in Western Australia from Spring 2013 to Summer 2018. (The data were obtained from the website for WA Police).

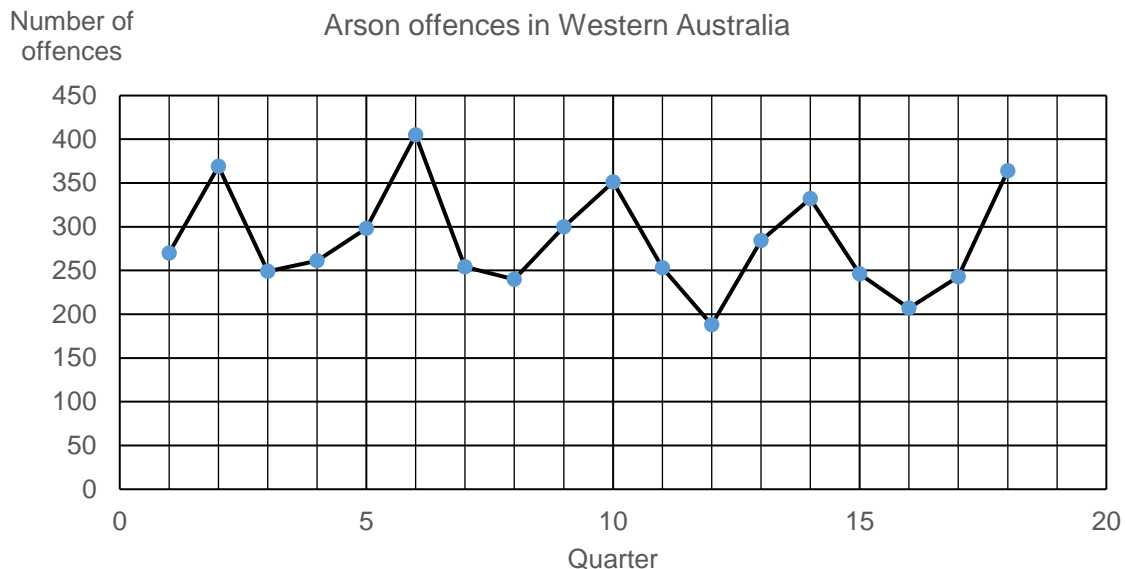

- (a) Describe the seasonality of the changes in the data and justify your conclusion with reference to at least one feature of the graph. (2 marks)

- (b) What appears to be the long-term direction of the number of arson offences occurring in Western Australia. Justify your conclusion. (2 marks)

Some of the data collected from the website are summarised on the next page

- (c) What season and year coincide with Quarter = 30? (1 mark)

- (d) Show the expression used to determine that the number of offences in Quarter 2 is 125% of the seasonal mean. (1 mark)

(e) Determine the seasonal index for Winter. (1 mark)

(f) Determine the deseasonalised number of arson offences for Winter 2017. (1 mark)

Number of arson offences in Western Australia

Quarter	Year	Season	Number of offences	Percentage of seasonal mean
1	2013	Spring	270	
2	2014	Summer	369	125%
3		Autumn	249	85%
4		Winter	261	89%
5		Spring	298	101%
6	2015	Summer	405	135%
7		Autumn	254	85%
8		Winter	240	80%
9		Spring	300	100%
10	2016	Summer	351	130%
11		Autumn	253	94%
12		Winter	188	70%
13		Spring	284	106%
14	2017	Summer	332	129%
15		Autumn	246	96%
16		Winter	207	81%
17		Spring	243	95%
18	2018	Summer	364	

Question 9

(6 marks)

The network below shows the capacity of different city bike paths in terms of the number of cyclists (in hundreds).

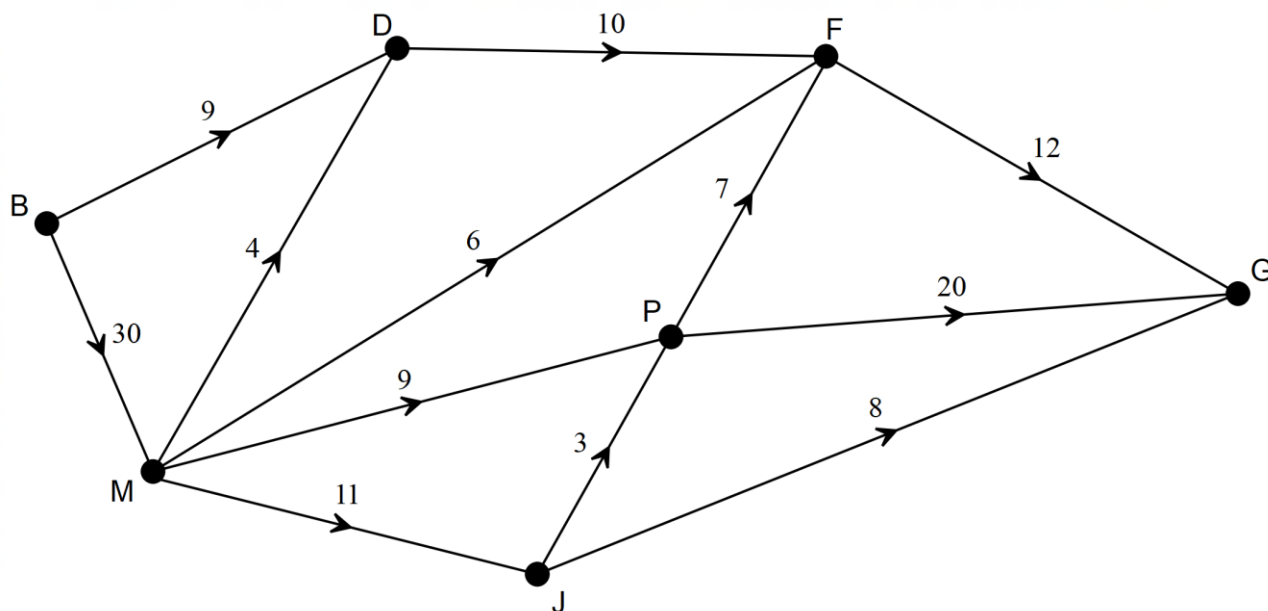

(a) Determine the maximum flow of cyclists through the network. List each path used and the corresponding number of cyclists. (4 marks)

(b) The path from P to F will be removed from the network.
How will this affect the maximum flow of cyclists? Explain your answer. (2 marks)

Question 10

(7 marks)

Tom's boat is valued at \$17 000 and is depreciating according to the recursive rule:

$$B_{n+1} = 0.94B_n$$

B_n represents the value of the boat after n years have passed.

- (a) Complete the table to show the value of the boat at the end of each of the first three years. (2 marks)

n	1	2	3
Value of boat after n years			

- (b) Determine the rate at which the value of the boat is depreciating. (1 mark)
- (c) How much value does the boat lose in the first year? (1 mark)
- (d) The amount by which the boat loses value each year is decreasing and yet the rate of the loss is constant. Explain. (1 mark)
- (e) Tom will sell the boat when it has lost more than \$10 000 in value. When will Tom sell the boat? (2 marks)

Question 11

(13 marks)

The following graph shows the 12 activities that need to be completed to finish a particular project as well as their completion times (days).

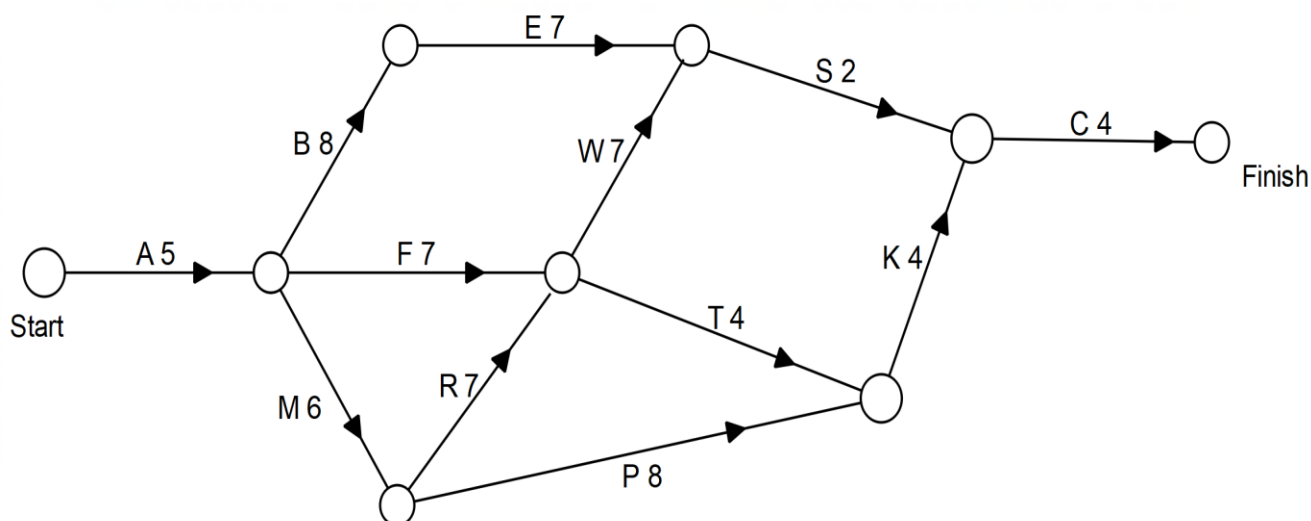

(a) State the critical path and the minimum completion time for this project. (2 marks)

(b) Determine the earliest starting time, the latest starting time and the float time for Activity K. (3 marks)

(c) Considering both the path and the time taken describe how the critical path is affected if

(i) Activity P takes 6 days longer than expected? (2 marks)

(i) Activity R takes 6 days longer than expected? (2 marks)

- (d) Complete the table below, listing all the activities, their immediate predecessors and the time for the activity. (4 marks)

Activity	Immediate Predecessors	Time (days)

Question 12

(12 marks)

The table below shows the monthly cost of council services and the median house price for some Perth suburbs.

Monthly cost of services (\$)	85	95	100	105	115	120	125	125	130	135
Median house price (thousands)	390	700	420	770	670	760	850	1100	850	1350

The graph below shows the values provided in the table.

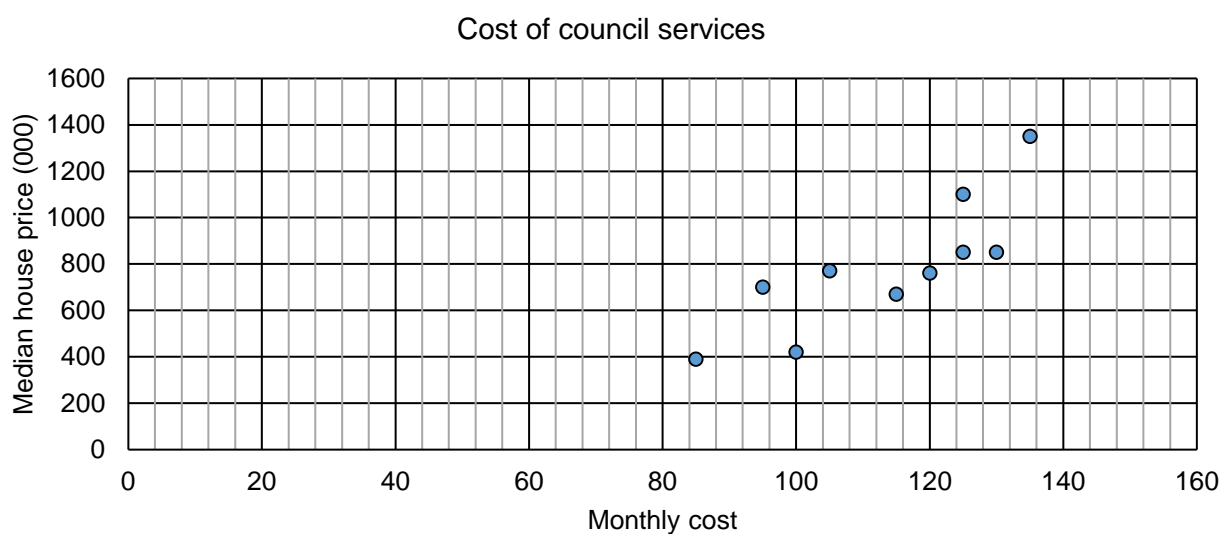

- (a) Describe the association between the two variables in terms of strength and direction. Justify your conclusions with reference to the graph provided. (4 marks)
- (b) Determine the equation of the least squares line for predicting the median house price from the monthly cost of council services. (1 mark)
- (c) Determine the correlation coefficient for this association. (1 mark)

The equation of the least squares line for predicting the median house price (H) from the monthly cost of council services (c) for a greater number of suburbs is as follows: $H = 13c - 640$ and the coefficient of determination is 0.81.

- (d) Use the given equation to predict the median house price when the monthly cost of council services is \$90. (2 marks)
- (e) Give TWO reasons to justify the conclusion that this prediction is reliable. (2 marks)
- (f) What percentage of the variation in the median house price can be explained by the variation in the monthly cost of council services? (1 mark)
- (g) For the linear model provided, state the predicted rise in the median house price when the monthly cost of council services increases by \$10. (1 mark)

Question 13

(13 marks)

James borrows \$25 000 to purchase a car. His monthly repayments are \$250. He is charged Interest at an annual rate of 8.4% and the interest is added monthly to his loan.

The table below shows the balance of his loan for the first three months.

Month	Account balance at the beginning of the month	Interest	Repayment	Account balance at the end of the month
1	\$25 000.00	\$175.00	\$250.00	\$24 925.00
2	\$24 925.00	\$174.48	\$250.00	\$24 849.48
3	\$24 849.48	\$173.95	\$250.00	\$24 773.42
4				

(a) Determine the monthly interest rate. (1 mark)

(b) State the recursive rule to calculate the balance in the account at the end of each month. (2 marks)

(c) Complete the details for the fourth month. Round all values to the nearest cent. (4 marks)

After the first 5 years James still owes \$19 431.40 on the loan.

(d) How much interest has James paid at the end of the first 5 years? (2 marks)

(e) James thinks that he could pay off the loan more quickly if he repaid his loan in two equal amounts each month with one at the beginning and one halfway through the month. Will this help James to pay off his loan more quickly? Justify your conclusion. (2 marks)

(f) James increases his repayments to \$300 per month at the end of the first 5 years. When will James pay off the loan? (2 marks)

Question 14

(14 marks)

The graph below shows the amounts charged for water consumption. Accounts are sent out every two months.

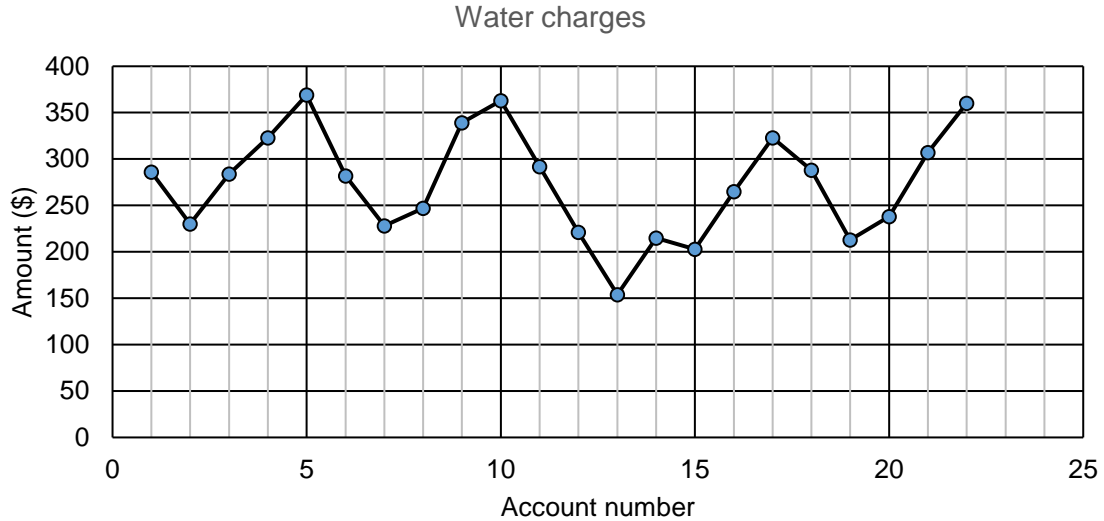

The table below shows data for the last 10 water accounts. The amounts have been rounded to the nearest dollar.

Account number	15	16	17	18	19	20	21	22	23	24
Amount (\$)	203	265	323	288	213	238	307	360	343	307

- (a) Determine the 6-point moving average at Account number = 19. (2 marks)
- (b) Explain why a 6-point moving average is appropriate for these data. (1 mark)
- (c) The graph does not show the last two amounts. Add them to the graph above. (1 mark)
- (d) For account numbers 4 to 21, the equation of the least-squares line for the moving average (M) against the account number (n) is $M = -1.6n + 290$. Draw this line on the graph above. (3 marks)

The graph below shows the daily water usage over the same period of time. The data are seasonal, and each cycle consists of 6 data points.

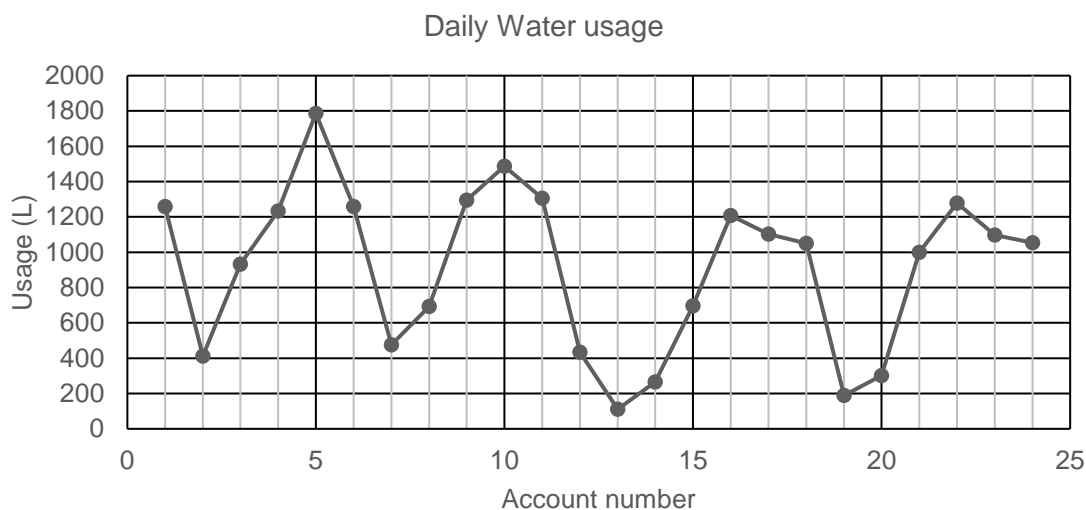

For these data the seasonal indices are provided in the table below.

Season	July	September	November	January	March	May
Seasonal index	27%	45%	112%	156%	158%	101%

- (e) Account number 1 shows the daily water usage for July 2014 and the accounts are provided every two months. Which month and year are represented in Account 25? (1 mark)
- (f) Determine the account number most likely to be associated with an outlier for daily water usage. Circle this outlier on the graph. (1 mark)
- (g) The equation of the least-squares line for deseasonalised data against account number for the more recent data is $D = 36n + 68$. Using this model
- (i) Predict the water usage for Account number 25. (3 marks)
- (ii) Comment on the reliability of your prediction made in part (i). (2 marks)

Question 15

(11 marks)

The graph shows the results for 10 different countries in an international test of Mathematics. One of the variables is the country's mean score (s) and the other is the percentage of students who have reached the highest level of achievement (p).

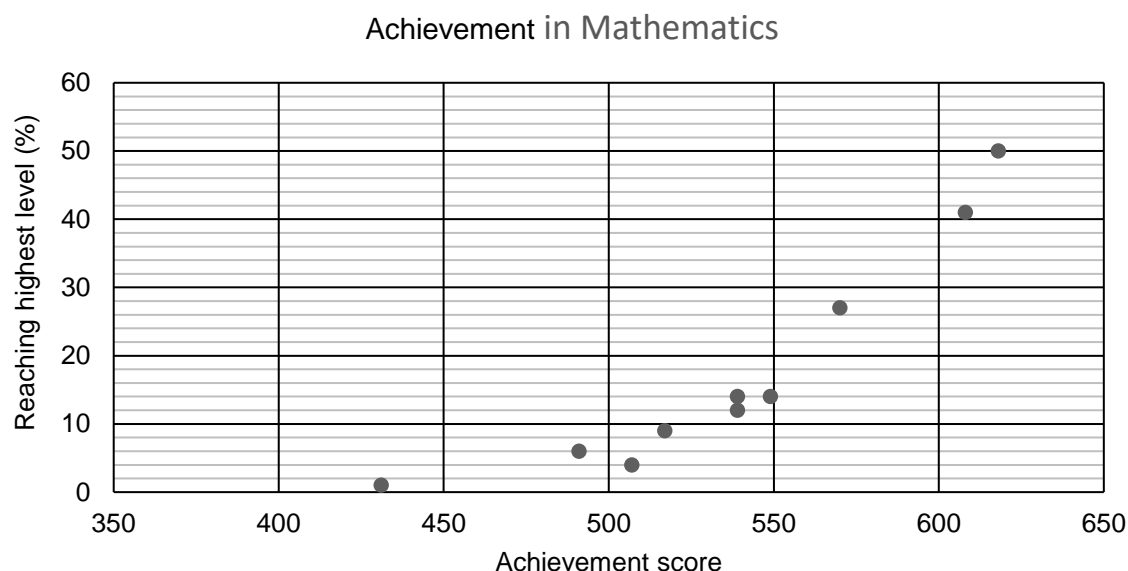

- (a) Explain why one should expect an association between the two variables. (1 mark)

The data for these 10 countries are analysed and the least-squares line that models a linear relationship between the two variables is determined to be $p = 0.27s - 127$. The coefficient of determination is 0.8276.

The table below shows the two data values for each country and then the predicted value (P) for the percentage of students determined to reach the highest level according to the linear model.

Country	1	2	3	4	5	6	7	8	9	10
s	618	608	549	539	507	491	570	431	517	539
p	50	41	14	14	4	6	27	1	9	12
P	40	37	21	19	10	6	27	-11	13	19

- (b) How many countries have a higher than predicted percentage of students reaching the highest level of achievement? (1 mark)

- (c) Create a scattergraph of the residuals against account number on the grid provided.
Label your axes clearly. (5 marks)

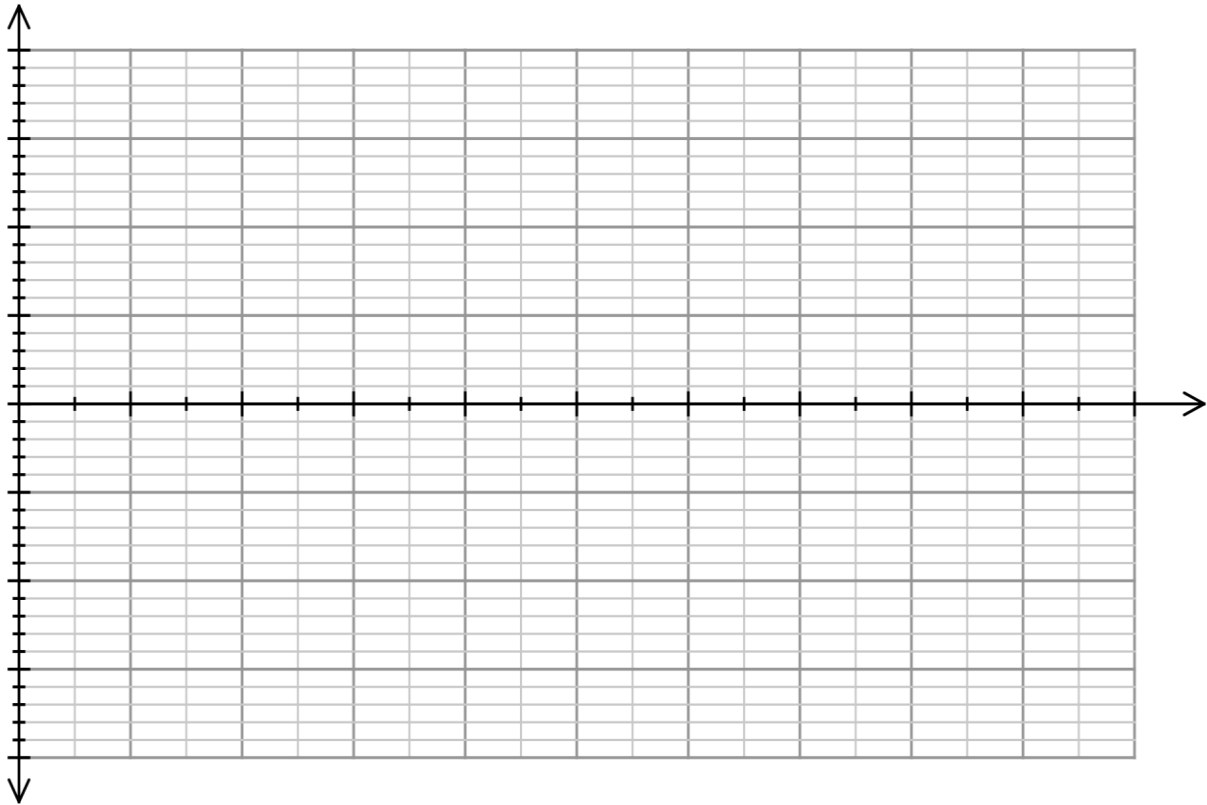

- (d) Use your residual plot to identify and describe the appropriateness of fitting this linear model to the data. (2 marks)

- (e) Use the information provided in the question to comment on the reliability of using this linear model to make predictions about the percentage of students who reach the highest level when given the country's mean achievement score. (2 marks)

Question 16

(10 marks)

The graph below shows some of the bushwalking tracks in a national park.

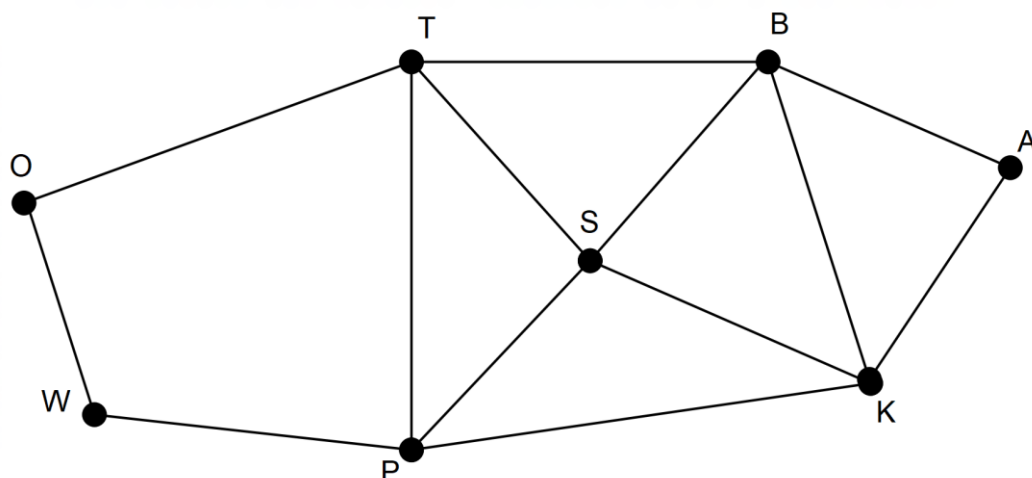

- (a) By identifying the number of faces, edges and vertices, verify that Euler's formula applies to this network. (4 marks)

- (b) Explain why the walk TBAKSPT can be called a cycle. (2 marks)

- (c) The ranger needs to check the tracks regularly. Identify a route that starts at the office (O), and for which there is no need to go over the same track twice. (2 marks)

- (d) The graph can be identified as Eulerian. Describe two features of this graph which justify this conclusion. (2 marks)

End of Questions

Additional working space

Question number: _____

Acknowledgements

Data for the number of arson offences in Western Australia was sourced from the website for the W.A. Police.

© MAWA, 2018

This examination is Copyright but may be freely used within the school that purchases this licence.

- The items that are contained in this examination are to be used solely in the school for which they are purchased.
- They are not to be shared in any manner with a school which has not purchased their own licence.
- The items and the solutions/markings keys are to be kept confidentially and not copied or made available to anyone who is not a teacher at the school. Teachers may give feedback to students in the form of showing them how the work is marked but students are not to retain a copy of the paper or marking guide until the agreed release date stipulated in the purchasing agreement/licence.

*Published by The Mathematical Association of WA
12 Cobbler Place, MIRRABOOKA 6...*